

COF

Compact Offline Filter

Our smallest unit yet, the Compact Offline Filter is able to fit where no other filtration equipment can. Ideal for smaller systems, or where a larger offline system wouldn't fit, can be permanently installed or portable.

Typical applications include gear boxes, plastic injection molding machines, and vacuum pumps, to name a few. Choose between a variety of motors, wands, hoses, and portable cart options. Paired with our unique VTM elements, this unit can remove particulate, water, and varnish all with one filter.

Donaldson.
HY-PRO™

hyprofiltration.com/



Small size, huge results.

The vertical design allows the installation of equipment with limited space compared to filter panels or other offline filtration equipment. At only 8.5" depth, 8" wide, and 27.75" tall, the COF can be installed on almost any piece of industrial or mobile equipment.



High viscosity performance.

The custom-designed gerotor pump was specifically designed to allow for a higher viscosity range than competing units. The COF can pump up to a 2,200 cSt fluid, equivalent to an ISO 460 oil at room temperature. This increasing the range of applications that are suitable without adding bulky heater options.



Wide range of media options.

Choose between a variety of media options from our G8 dualglass (M), G8 dualglass + water-absorbing (A), or VTM media. VTM710 media is the ideal filter media choice to pair with the COF to remove particulate, water, and varnish. Our G8 dualglass media is another excellent option. Rated at an industry-leading Beta 4000 value, G8 dualglass media was developed using our proprietary Dynamic Filter Efficiency (DFE) test standard. Rest assured, our filter medias deliver cleanliness in the real world, whichever option you choose.

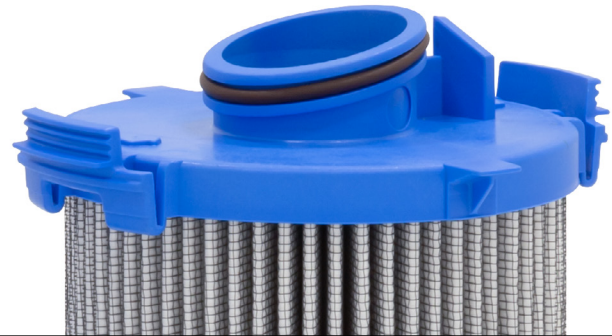

Easy filter element servicing.

Only 1.5" of clearance is required for element servicing since the bowl and filter are removed as a single piece. The element snaps into the bowl and is automatically seated to the pump as the bowl is installed. A bowl drain comes standard as well as a hex nut for easy removal and installation. The required torque is listed on the bowl for easy reference during servicing.



Reverse flow element with integrated bypass.

The HP482 filter elements used in the COF utilize a reverse flow element with a bypass valve integrated into the closed end cap. The raised bypass design keeps dirt in the bottom end cap during bypass and element servicing. Every time an element is changed, a new bypass is installed eliminating bypass valve fatigue and leakage over time.

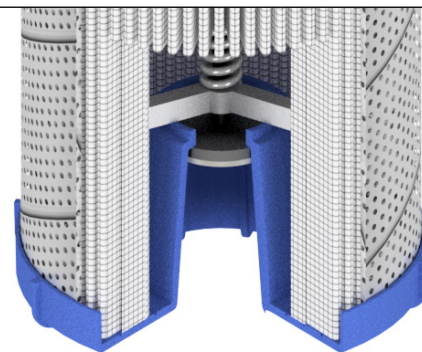

Dedicated to reliability.

Don't let dirty oil get you down. Clean oil is essential to the long-term reliability of all equipment. At Donaldson Hy-Pro we are dedicated to the removal of all forms of oil contamination from dirt to water and even varnish and sludge removal. Extend the life of your oils as well as high pressure, return, and pilot filter elements with an easy to service, compact off-line filter.



COF Quick Guide

COF1512S-FW-Y** model shown

Stainless Steel hose wands (optional).....

Portable cart (optional)

Electric Motor.....

Suction and return hoses (optional).....

Custom designed gerotor pump.....

Restriction indicator (optional)

Upstream sample port

Bowl/cartridge design with HP482RNL11



Filter Sizing Guidelines

Filter Sizing Guidelines and Viscosity Conversion

Effective filter sizing requires consideration of flow rate, viscosity (operating and cold start), fluid type and degree of filtration. When properly sized, bypass during cold start can be avoided/minimized and optimum element efficiency and life achieved. The filter assembly differential pressure values provided for sizing differ for each media code, and assume 32 cSt (150 SUS) viscosity and 0.86 fluid specific gravity. Use the following steps to calculate clean element assembly pressure drop.

Calculate ΔP coefficient for actual viscosity

Using Saybolt Universal Seconds (SUS)

$$\Delta P \text{ Coefficient} = \frac{\text{Actual Operating Viscosity}^1 \text{ (SUS)}}{150} \times \frac{\text{Actual Specific Gravity}}{0.86}$$

Using Centistokes (cSt)

$$\Delta P \text{ Coefficient} = \frac{\text{Actual Operating Viscosity}^1 \text{ (cSt)}}{32} \times \frac{\text{Actual Specific Gravity}}{0.86}$$

Calculate actual clean filter assembly ΔP at both operating and cold start viscosity

$$\text{Actual Assembly Clean } \Delta P = \text{Flow Rate} \times \frac{\Delta P \text{ Coefficient (from calculation above)}}{\text{Assembly } \Delta P \text{ Factor (from sizing table)}}$$

Sizing recommendations to optimize performance and permit future flexibility

- To avoid or minimize bypass during cold start the actual assembly clean ΔP calculation should be repeated for start-up conditions if cold starts are frequent.
- Actual assembly clean ΔP should not exceed 10% of bypass ΔP gauge/indicator set point at normal operating viscosity.
- If suitable assembly size is approaching the upper limit of the recommended flow rate at the desired degree of filtration consider increasing the assembly to the next larger size if a finer degree of filtration might be preferred in the future. This practice allows the future flexibility to enhance fluid cleanliness without compromising clean ΔP or filter element life.
- Once a suitable filter assembly size is determined consider increasing the assembly to the next larger size to optimize filter element life and avoid bypass during cold start.
- When using water glycol or other specified synthetics we recommend increasing the filter assembly by 1~2 sizes.

COF Filter Sizing Guidelines

ΔP Factors ¹	Series	Length	Units	Media						
				1M	3M	6M	10/12M	16M	25M	**W
HP482RN	L11		psid/gpm	0.230	0.164	0.128	0.103	0.095	0.028	0.007
				bard/lpm	0.004	0.003	0.002	0.002	0.002	0.002
				1A	3A	6A	10/12A	16A	25A	VTM710
				psid/gpm	0.264	0.185	0.142	0.112	0.102	0.034
				bard/lpm	0.005	0.003	0.003	0.002	0.002	0.007

¹Max flow rates and ΔP factors assume $\beta = 150$ SUS, 32 cSt. See filter assembly sizing guideline for viscosity conversion formula.

Length	A	B	C	D	E	F
12	3.00 in 76.2 mm	4.88 in 124.0 mm	3.41 in 86.5 mm	20.76 in 527.3 mm	0.35 in 8.9 mm	-
24	3.00 in 76.2 mm	4.88 in 124.0 mm	3.58 in 90.8 mm	20.31 in 516.0 mm	0.34 in 8.6 mm	3.67 in 93.3 mm
46	3.00 in 76.2 mm	4.88 in 124.0 mm	3.91 in 99.3 mm	20.28 in 515.2 mm	0.33 in 8.5 mm	-

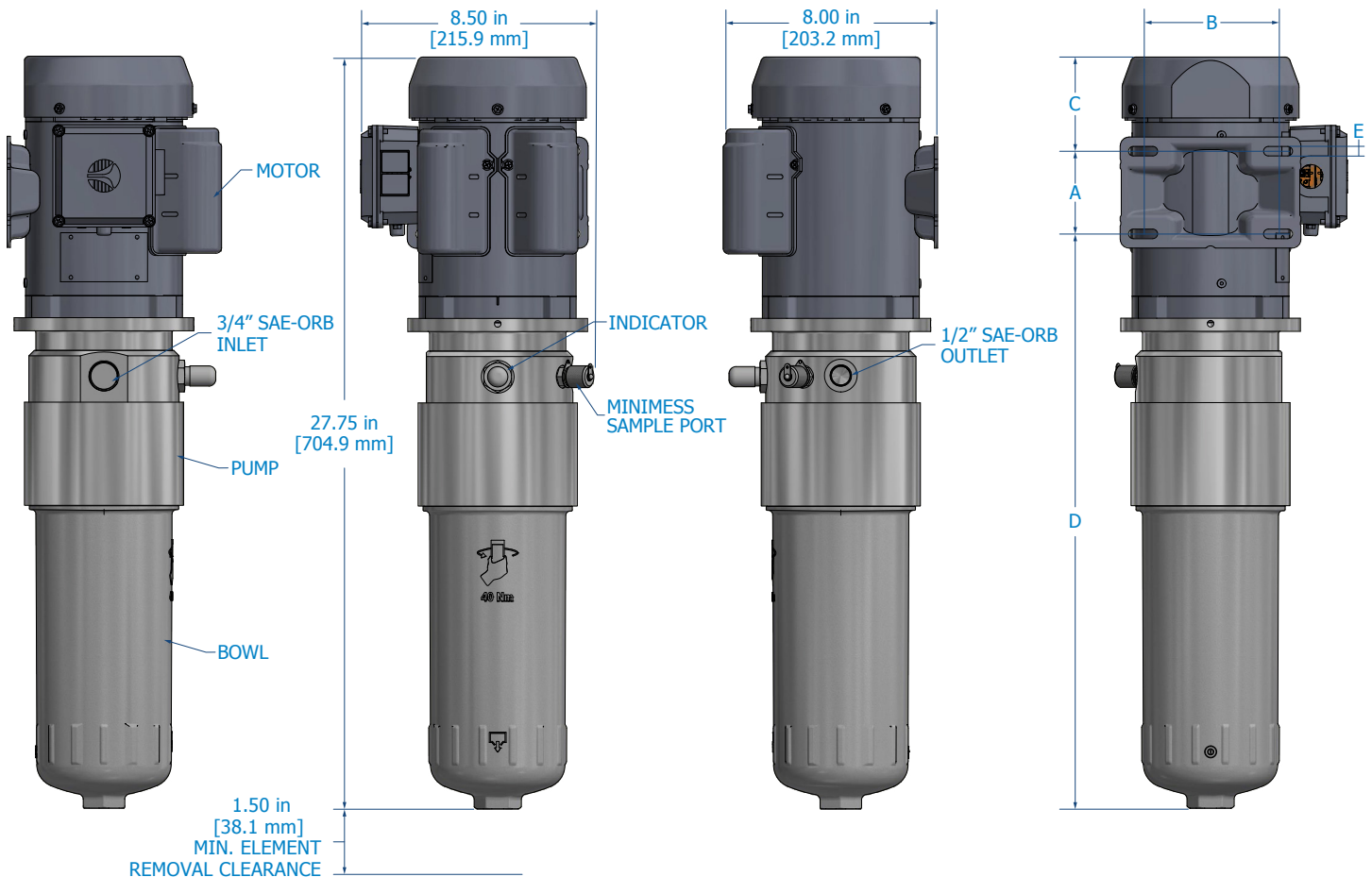
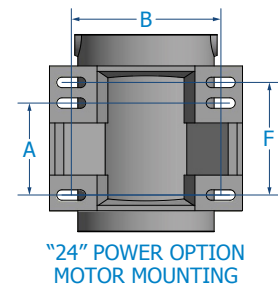

COF Specifications

Dimensions¹ Without frame With frame	Height 8.5" (22 cm) 58" (147 cm)	Length 27.75" (70 cm) 24" (61 cm)	Width 8" (20 cm) 21" (53 cm)	Weight 35 lbs (16 kg) 112 lbs (51 kg)		
Connections	Inlet ¾" female SAE-ORB	Outlet ½" female SAE-ORB	Hoses ¾" x 8 ft (2.4 m) suction female JIC or BSPP swivel ½" x 8 ft (2.4 m) discharge female JIC or BSPP swivel			
Operating Temperature	Fluid Temperature 30°F to 225°F (0°C to 105°C)		Ambient Temperature -4°F to 104°F (-20C to 40C)			
ΔP Indicator Trigger	35 psi (2.4 bar).					
Filter Assembly Bypass	50 psid (3.4 bard).					
Materials of Construction	Motor Steel cover	Pump Aluminum body	Filter Assembly Aluminum bowl	Hoses Reinforced synthetic	Wands Stainless steel	Element End Caps Nylon glass filled
Power Options Contact factory for options not listed	1/2 HP, 1P, 115/208-230 V ac, 60Hz, with on/off switch, 6 foot cord, and NEMA 5-15 plug 1/2 HP, 1P, 60Hz and 50Hz 1/2 HP, 3P 208-230/460 V ac, 60Hz 1/2 HP, 3P 190/380 V ac, 50Hz 1/2 HP, 24 V dc, 20 A, Electric Motor					
Pump	Custom designed positive displacement gerotor pump with internal relief valve.					
Media Description	M G8 Dualglass, our latest generation of DFE rated, high performance glass media for all hydraulic & lubrication fluids. $\beta_{x_{[c]}} \geq 4000$	A G8 Dualglass high performance media combined with water removal scrim. $\beta_{x_{[c]}} \geq 4000$	VTM $\beta_{0.9_{[c]}} \geq 4000$ particulate, insoluble oxidation by-product and water removal media			
Replacement Elements	To determine replacement elements, use corresponding codes from your equipment part number:					
	Model COF15	Filter Element Part Number HP482RNL11 – [Media Selection Code] [Seal Code]		Example HP482RNL11-3MB		
Viscosity	1-2200 cSt Maximum viscosity based on dedicated COF installations with positive inlet flooded suction. Contact factory for portable COF maximum recommended viscosity with hoses and wands.					
Fluid Compatibility	Petroleum and mineral based fluids (standard). For polyol ester, phosphate ester, and other specified synthetic fluids use fluorocarbon seal option or contact factory.					

¹Dimensions are approximations taken from base model and will vary according to options chosen.

COF Part Number Builder



Model	Filter Rate	Filter Elements
	15 1.5 gpm (5.7 lpm)	HP482RNL11-***

Power Options Contact factory for options not listed	11	1/2 HP, Single Phase, 115 V Ac, 50 Hz, Electric Motor With ON/OFF Switch, 6 Foot Cord, And No Plug
	12	1/2 HP, 1P, 115/208-230 V ac, 60Hz and 50Hz, with on/off switch, 6 foot cord, and NEMA 5-15 plug
	21	1/2 HP, Single Phase, 208-230 V Ac, 50 Hz, Electric Motor With ON/OFF Switch, 6 Foot Cord, And No Plug
	22	1/2 HP, Single Phase, 208-230 V Ac, 60 Hz, Electric Motor With ON/OFF Switch, 6 Foot Cord, And No Plug
	23	1/2 HP, 3 Phase 208-230 V Ac, 60 Hz, Electric Motor
	24	1/2 HP, 24 V dc, 20 A, Electric Motor
	40	1/2 HP, 3 Phase 380-400 V Ac, 50 Hz, Electric Motor
	46	1/2 HP, 3P 208-230/460 V ac, 60Hz 1/2 HP, 3P 190/380 V ac, 50Hz

Hose Connection	G	8 foot hoses, female BSP swivel hose ends
	S	8 foot hoses, female JIC swivel hose ends
	X	No hoses

ΔP Indicator	Indicator Options		Thermal Lockout	Surge Control	Reset
	D	Visual / Electrical (DIN 43650)	No	No	Auto
	S	Visual / Electrical (DIN 43650)	Yes	Yes	Manual
	T	Visual / Electrical (DIN 43650)	Yes	No	Manual
	V	Visual	No	No	Auto
	X	No indicator (port plugged)	-	-	-
	Y	Visual	Yes	Yes	Manual

Special Options	F	Portable cart frame
	U	CUL and/or CSA marked starter enclosure for Canada
	W	Stainless Steel wands

Media Selection	G8 Dualglass		G8 Dualglass + water removal		VTM VTM710 β _{0.9} (c) = 4000 particulate, insoluble oxidation by-product and water removal media
	1M	β ₃ (c) ≥ 4000	3A	β ₄ (c) ≥ 4000	
	3M	β ₄ (c) ≥ 4000	6A	β ₆ (c) ≥ 4000	
	6M	β ₆ (c) ≥ 4000	10A	β ₁₁ (c) ≥ 4000	
	10M	β ₁₁ (c) ≥ 4000	16A	β ₁₆ (c) ≥ 4000	
	16M	β ₁₆ (c) ≥ 4000	25A	β ₂₂ (c) ≥ 4000	
	25M	β ₂₂ (c) ≥ 4000			

Seals	B	Nitrile (Buna)
	V	Fluorocarbon
	E-WS	EPR seals + stainless steel support mesh

For all up to date option details and compatibilities, please reference our Contamination Solutions Price List or contact customer service.



Filtration starts with the filter.

Lower ISO Codes: Lower Total Cost of Ownership

Donaldson Hy-Pro filter elements deliver lower operating ISO Codes so you know your fluids are always clean, meaning lower total cost of ownership and reducing element consumption, downtime, repairs, and efficiency losses.

DFE Rated Filter Elements DFE is Donaldson Hy-Pro's proprietary testing process which extends ISO 16889 Multi Pass testing to include real world, dynamic conditions and ensures that our filter elements excel in your most demanding hydraulic and lube applications.

Upgrade Your Filtration Keeping fluids clean results in big reliability gains and upgrading to Donaldson Hy-Pro filter elements is the first step to clean oil and improved efficiency.

Advanced Media Options DFE glass media maintaining efficiency to $\beta_{3[\text{c}]} > 4000$, Dualglass + water removal media to remove free and emulsified water, stainless wire mesh for coarse filtration applications, and Dynafuzz stainless fiber media for EHC and aerospace applications.

Delivery in days, not weeks From a massive inventory of ready-to-ship filter elements to flexible manufacturing processes, Donaldson Hy-Pro is equipped for incredibly fast response time to ensure you get your filter elements and protect your uptime.

More than just filtration Purchasing Donaldson Hy-Pro filter elements means you not only get the best filters, you also get the unrivaled support, training, knowledge and expertise of the Donaldson Hy-Pro team working shoulder-to-shoulder with you to eliminate fluid contamination.



Want to find out more? Get in touch.

hyprofiltration.com
info@hyprofiltration.com
+1 317 849 3535

© 2024 Donaldson Company, Inc. All rights reserved.



F119885-080624-EM